

# salefino ponteggi

ponteggi elettrici, montacarichi, ascensori da cantiere

noi progettiamo  
noi costruiamo



Piattaforma di trasporto porta materiali e porta persone  
*Transport platform for people and material*

**MT 500 TM**  
con selettore Trifase - Monofase

# MT 500 TM (Max capacity: 400/800 Kg)

con selettore Trifase-Monofase - with selection Three phase-Single phase  
с однофазным/трёхфазным переключателем

Piattaforma di trasporto porta materiali e porta persone  
Transport platform for people and material

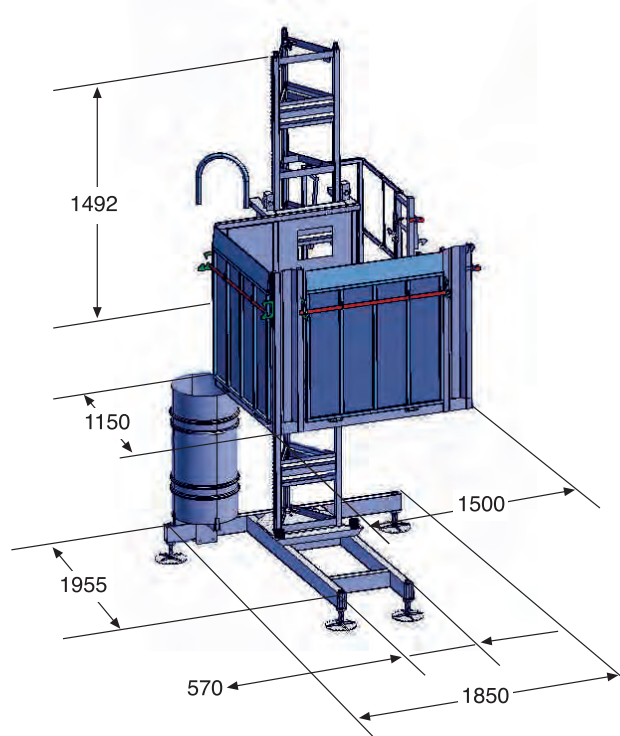
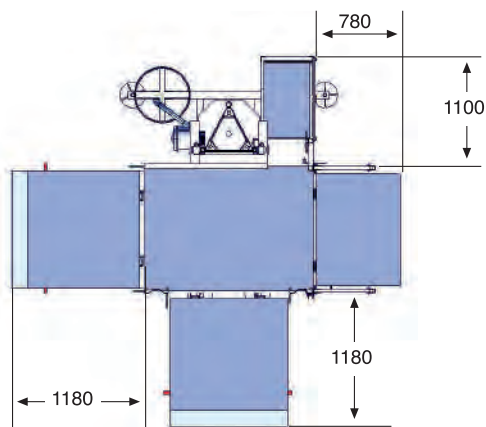

<b>MT 500 TM</b>	800 Kg.	
	700 Kg.	
	600 Kg.	
	500 Kg.	
	400 Kg.	

DATI TECNICI	TECHNICAL DATA	DONNÉES TECHNIQUES	ТЕХНИЧЕСКИЕ ДАННЫЕ	
Dimensione cesta	Cage dimensions	Dimensions cabine	Размеры кабины	1150 mm x 1500 mm x 1100 mm *
Dimensioni dell'unità di base	Base unit dimensions	Encombrement	Размеры базы	1955 mm x 1850 mm
Peso traliccio	Trellis weight	Poids pylône	Вес секции	41 kg
Velocità di sollevamento	Lifting speed	Vitesse de levage	Скорость подъема	12 m/min
Massima altezza ancorata	Max anchored height	Hauteur max avec ancrages	Мах. высота с анкерными креплениями	120 m
Tensione di alimentazione	Supply voltage	Tension d'alimentation	Напряжение питания	230/400/50 Hz
Interruttore protezione linea	Protection switch	Interrupteur de protection	Защитный выключатель линии	16 A
Potenza servizio continuo	Power of the motors	Puissance moteur	Мощность двигателя	1 x 2,2 Kw
Corrente di spunto	Starting current	Ampérage au démarrage	Сила тока	66 A
Minima potenza di linea consigliata	Suggested minimum line power	Min. puissance de ligne conseillée	Минимальная рекомендуемая мощность линия	6 kW

\* Per dimensioni diverse, contattare il costruttore - Please contact the manufacturer for different size  
Contactez le fabricant pour les différentes tailles - Связаться с производителем для других размеров



Salerno Ponteggi s.r.l.  
via Wenner, 57 - 84131 Salerno  
Tel. +39 089 842 35 91 Fax +39 089 842 35 93  
www.salernoponteggi.it - ufficiomarketing@salernoponteggi.it